

ARK

3通直动型电磁阀 3-Port Direct Operated Solenoid Valve Series **KSV200**

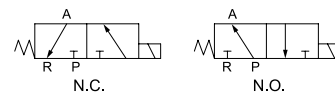

KSV211-5D

规格 Specifications

型号 Model	KSV211	KSV212
切换方式 Actuation	常闭 N.C.	常开 N.O.
使用流体 Fluid	过滤压缩空气 Filtered compressed air	
接管口径 Port size	M5	
使用压力范围 Operating pressure range (MPa)	0~0.8	
口径 Orifice (mm)	P=Ø1.1, R=Ø1.2	P=Ø1.2, R=Ø1.1
环境及流体温度 Ambient and fluid temperature	5~60°C	
响应时间 Response time (0.5 MPa)	≤ 20 ms	
最大工作频率 Maximum working frequency	8 c/sec	
* 润滑 Lubrication	不需要 Not required	
手动方式 Manual override	按钮无锁定 (标准), 旋转锁定 (可选) Push button non-locking (standard), lever locking (option)	
额定电压 Rated voltage	AC110V, AC220V (50/60 Hz), DC12V, DC24V	
容许电压波动范围 Permissible voltage variation	±10% 额定电压 ±10% of rated voltage	
线圈绝缘等级 Coil insulation class	F 或同等等级 Class F or equivalent	
功率消耗 Power consumption	AC	持续 Holding 3.5 VA (50/60 Hz)
	DC	2.5 W

* 如需润滑请使用透平 1 号油 ISO VG32#. Please use 1st Grade Turbine Oil ISO VG32# if necessary.

型号表示方法 How to Order

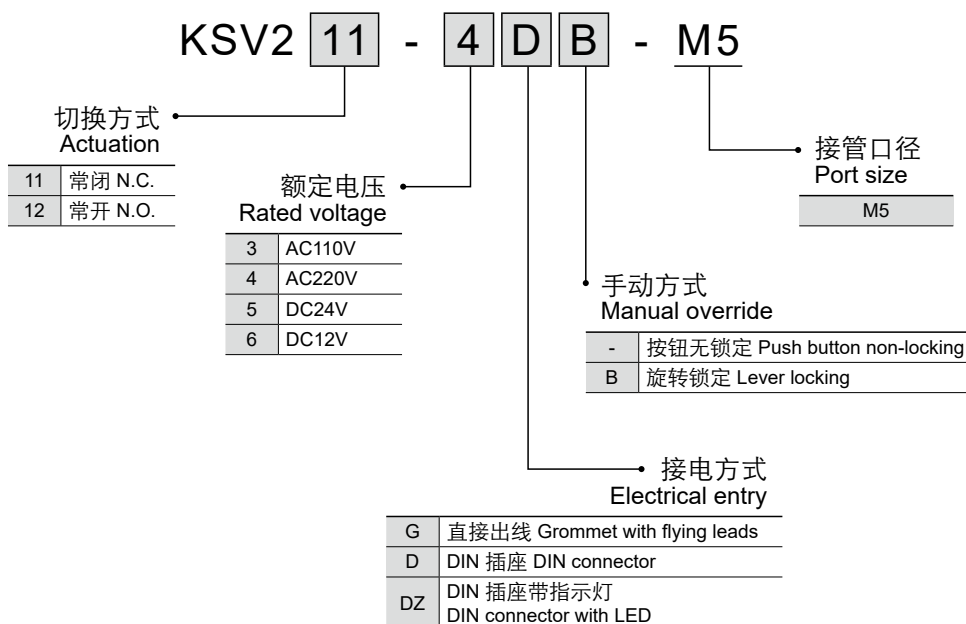

3通直动型电磁阀

3-Port Direct Operated Solenoid Valve

Series KSV200

外形尺寸图 Dimensions (mm)

KSV211-G/KSV212-G

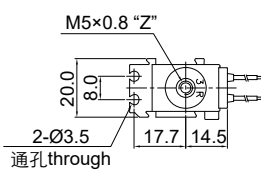

Type	N.C.	N.O.
Port X	P(1)	R(3)
Port Y	A(2)	A(2)
Port Z	R(3)	P(1)

KSV211-D(DZ)/KSV212-D(DZ)

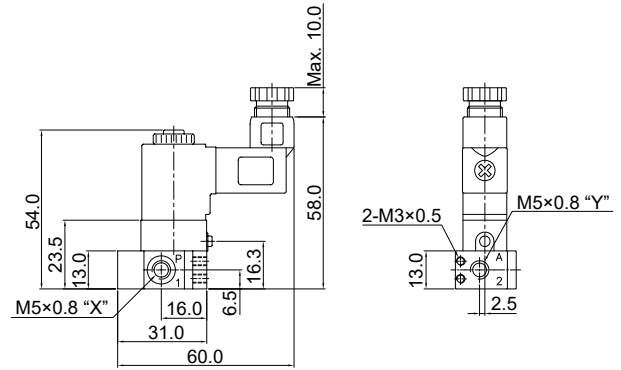
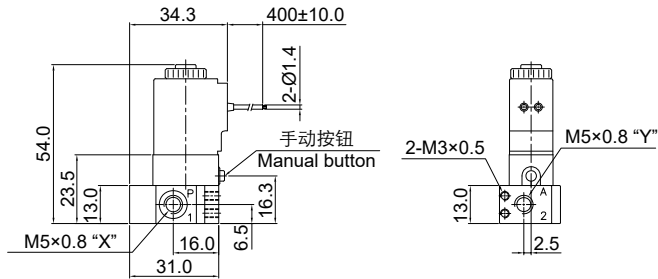
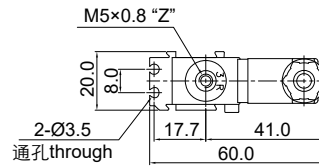

2

汇流板 Manifold

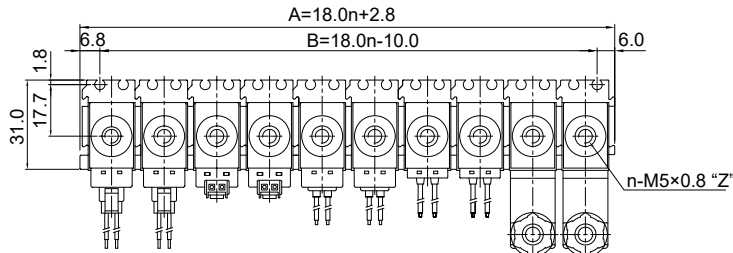

n=位置数 No. of stations

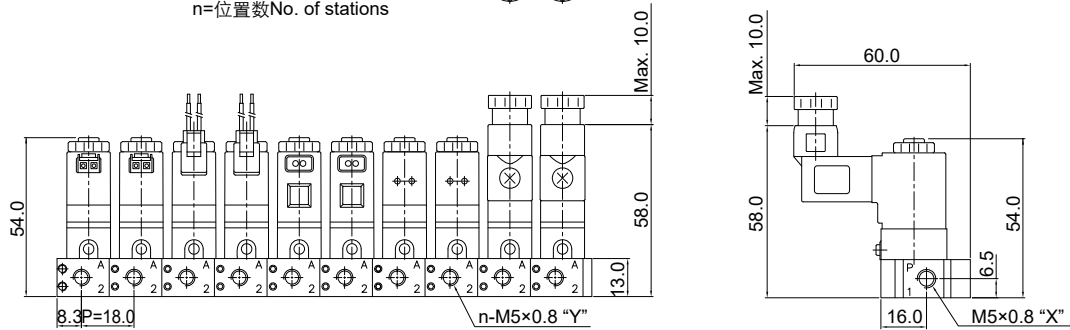

位置数 No. of stations n	2	3	4	5	6	7	8	9	10
A	38.8	56.8	74.8	92.8	110.8	128.8	146.8	164.8	182.8
B	26	44	62	80	98	116	134	152	170